



Structural Design and Strength Analysis of Lifting Machine for Home Appliance Flood Safety Tool: A Problem-based Learning

Gabriel Ayrton Andares Sineri^{1,2}, Astrid Vanya Octary^{1,2}, Muchammad Fachrizal Ali^{1,2}, Nurlaely Rohmatul Iza^{1,2}, Farid Triawan¹

¹ Department of Mechanical Engineering, Faculty of Engineering and Technology, Sampoerna University, Jakarta, 12780, Indonesia

² Department of Aerospace and Mechanical Engineering, The University of Arizona, Tucson, AZ, 85721, USA.

Correspondances: E-mail: farid.triawan@sampoernauniversity.ac.id,

gabriel.sineri@my.sampoernauniversity.ac.id

ABSTRACTS

In Indonesia, floods become an annual disaster, especially in the rainy season. The number of floods occurs in Indonesia in 2019 reached 1,277 cases. The floodwater can cause massive damage to the home appliance, especially when contacted with electronic devices. Moreover, the lifting machine comes as an excellent solution, securing the electronic device when floods come. A preliminary design of a hydraulic scissors lifter for elevating the home appliance during floods is introduced along with its static and fatigue strength analyses. The proposed design comes up with a combination of scissors lifter mechanism combined with the hydraulic jack device. The analyses in the critical components of the lifting machine - the support link and the scissors rod link - are presented. The lowest and upper conditions are assumed and resulted in a dynamic safety factor of 1.252 for the lowest position and 3.11 for the highest position. These values indicate that the proposed design offers excellent safety. Additionally, this work can be classified as teaching material for the machine element course.

© 2021 Kantor Jurnal dan Publikasi UPI

ARTICLE INFO

Article History:

Submitted/Received 28 Apr 2021

First revised 08 May 2021

Accepted 09 Jun 2021

First available online 11 Jun 2021

Publication date 01 Sep 2021

Keyword:

Flood Safety Tool,
Lifting Machine,
Problem-based learning,
Strength analysis,
Structural design.

1. INTRODUCTION

Floods as natural disasters bring many disadvantages, not only as a threat to human life but also financial loss (Tambunan, 2017). In Indonesia, floods become an annual disaster, especially in the rainy season. The number of floods in Indonesia in 2019 reaches 1.277 cases (Statista Research Department, 2021). When floods happen, the most significant damage occurs to the home appliance, especially the electrical device such as television, computer, and fridge. Electrical gear and wiring may not work as expected, and there might be fire and stun dangers due to openness to dampness and toxins in floodwater.

In order to minimize the damage from the floodwater to the electrical device, one of the popular options is to build a lifter device. The lifter device may help to secure the electronic device when a flood occurs. Furthermore, safety concern is given urgency to the electrical device safety and user comfortability, therefore each design should follow specific criteria. Additionally, hi-lift, generally recognized as scissors lifts, are fundamental structures supporting the lifter device. The scissor lifts should be designed to support the highest load and stress around several approaches. So, it does not fail throughout the procedure (Rashid et al., 2012).

Hydraulic System is half of the system's primary task (lift loads), consisting of cross arms (X) linked between the highest and base platforms. Furthermore, it utilizes a particular style of energy. An electrical motor is an associate electrical device that converts the voltage into energy (Paramasivam et al., 2021). The hydraulic is the primary element for some scissors to elevate in a mechanical motion. That is why hydraulic scissors' supply for up and down movement elevates through the piston and pump (Bacchini et al., 2021; Kayhani et al., 2021).

This paper aims to design a lifting device that combines the scissors arm and hydraulic system. This lifting machine advantages to persons who want to elevate their electrical devices to secure from damage because of floodwater when floods happen. The proposed design needs to be a foldable hydraulically scissor lift with 150 kg capacity and a maximum high of up to 1.5 meters.

2. METHODS

2.1 Scissor-hydraulic lifting machine specification

The primary specification considers several factors such as the height, durability, and simplicity of the operation. The Scissor-hydraulic lifting machine was designed due to the urgency of finding a solution in reducing the financial loss because of the flood. For instance, people tend to move their home appliances into the high ground when flood to avoid the damage because of floodwater contact. The most critical one is electrical devices such as refrigerators, television, and any other big electronic device.

The maximum height of the mechanism is essential because of the dependency on the height of floodwater. The other necessary specification is the durability of the machine since the mechanism will contact the floodwater directly. Furthermore, simplicity on how the user operates the machine by the hydraulic jack mechanism can efficiently lift the home appliances when flood coming.

The secondary specification is the materials. The primary material for the structure should be produced in many options of dimension. The consideration in choosing a material is considered the strength of the material and considers other factors such as ductility and anti-corrosion. After the research process, there will be an isolator system for the steel using rubber to make the mechanism water-resistance. Therefore, the steel part and carjack will not quickly be being corrosive. Moreover, other considerations in choosing the material

depend on the availability, material sustainability, and the cost of materials. The most crucial consideration is that the material should be strong enough to maintain the weight of the refrigerator.

2.2 Prototype design modelling

After the specifications are decided, it continues to consider the design of the mechanism. Since the proposed design combines the hydraulic jack system and scaffolding, the primary consideration is to design scaffolding. The mechanism is rough, still not considering the specifications. The design dimension is 900 mm in length, 600 mm in width, and 1200 mm in high. Moreover, after discussing and analyzing the mechanism, it cannot hold the desired weight and cannot reach the desired height. It also has the reversed mechanism compared to the desired mechanism when the hydraulic carjack push mechanism will be going up. The dimension should need to change since it is not safe and did not match the desired specification.

2.3 Analysis and optimization

The final phases are the analysis and design optimization (Zulaikah *et al.*, 2020, Oktaviandri & Paramasivam, 2020). The design optimization process will consider the shape, dimension, and feature of the scissor lifting machine and hydraulic system to fit for use in flood. The first optimization is securing the hydraulic system with compact rubber insulation to make the device more sustainable. The insulation of the hydraulic is decreasing the damage of the floodwater to the hydraulic system.

The other optimization is design optimization by adjusting the scissors arm's dimension and doing the free body diagram (FBD) analysis, which essential in the analysis because it defines the scissor arm's forces. The forces exist such as reaction forces, gravitational force, maximum force once the component is lifting the load, in this case, are a fridge in the highest position, minimum force when it does the lowest position, as well as the distributed load. Moreover, the FBD, along with the shear-force diagram (SFD), also the bending moment diagram (BMD), will additionally be calculated. The strength calculation, along with SFD and BMD, are examined to get the maximum normal and shear stresses, and then calculate the safety factor.

The safety factor stands for the ratio of the ultimate stress towards the allowable stress utilized to the components. The ultimate stress is decided depending on the material used to design the part. Moreover, the allowable stress should be fewer than the ultimate stress to guarantee that the component will not fail under a certain loading. Two loads should be known to define the fatigue safety factor which are, the alternating and mid-range stresses. The Modified Goodman failure criterion calculates the fatigue safety factor. The value will determine the service life of the product. If the value already fits the criterion, the design can pass the optimization phase.

3. RESULTS AND DISCUSSION

3.1 Main materials

There are two primary materials used to make this product. The material used to make the support links is structural ASTM A36 steel which has several distinctions. The first is that ASTM A36 has a lower oxidation rate at room temperature (Sajid & Kiran, 2018). The second is that the microstructure of ASTM A36 is various, based on the treatment given (MF, 2016). Therefore, it is justified with the needs. The third is ASTM A36, commonly being chosen for

welded construction (Preedawiphath, et al., 2020). The mechanical properties of ASTM A36 are shown in **Table 1** below.

The other material used in this product is AISI 1060 Steel or carbon steel. The AISI 1060 material is used to make the links that are connected directly to the hydraulic car jack. This material was chosen because of the steel's chemical composition, which results in the hardness value of the material. **Table 2** showing the value of the hardness steel in type AISI 1060 (Çalik, 2009).

3.2 Final proposed design

The final design is the result of a discussion on how the mechanism reaches the desired specification. In the final design, the mechanism has reached the height of 1.5 m in the highest position, which matched with the desired mechanism. The final design is shown in **Figure 1**. The dimension of the plate is changing because to adjust the dimension of the refrigerator.

After reaching the desired height, the link that has an essential aspect in the mechanism is also adjusted due to the safety factor calculation. The detail of each component is shown in **Table 3**. The rod placed at the bottom (component 3) of the mechanism has a function combined with the hydraulic jack mechanism welded to each other since both of them use steel material. Therefore, when the hydraulic jack is operating, the mechanism will be going up and lifting the refrigerator. The detailed drawing for each component is shown in **Figure 2-5**.

Table 1 Mechanical properties of ASTM A36.

| Material | Yield Strength (N/mm ²) | Tensile Strength (N/mm ²) | Elongation (%) |
|----------|-------------------------------------|---------------------------------------|----------------|
| ASTM A36 | 250 | 400-550 | 23 |

Table 2 Hardness value of AISI 1060.

| Steel type | Hardness (HV _{0.1}) | | |
|---------------------|-------------------------------|------------|----------------|
| | Water Quenched | Air Cooled | Furnace Cooled |
| Steel C (AISI 1060) | 610 | 203 | 167 |

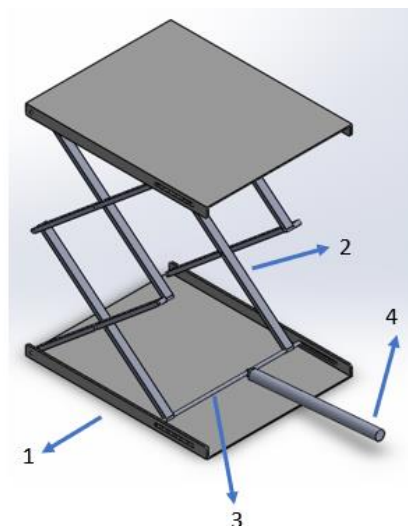

Figure 1. The final design of the scissors-hydraulic lifting machine.

Table 3 Dimension of each component.

| Part # | Name of components | Dimension (mm) | Function |
|--------|---------------------------------|-----------------------|---|
| 1 | Plate for refrigerator and Base | 1000 x 800 x 56 | As the place to put refrigerator and as the base of the mechanism |
| 2 | Link | 900 x 20 x 40 (8) | As the core for moving the mechanism goes up or down |
| 3 | Rod (1) | 800 x 10 (d) x 10 (d) | As the connector for link and/between the rod for hydraulic jack |
| 4 | Rod (2) | 350 x 40 (d) x 40 (d) | As the connector between hydraulic jack and rod (1) |

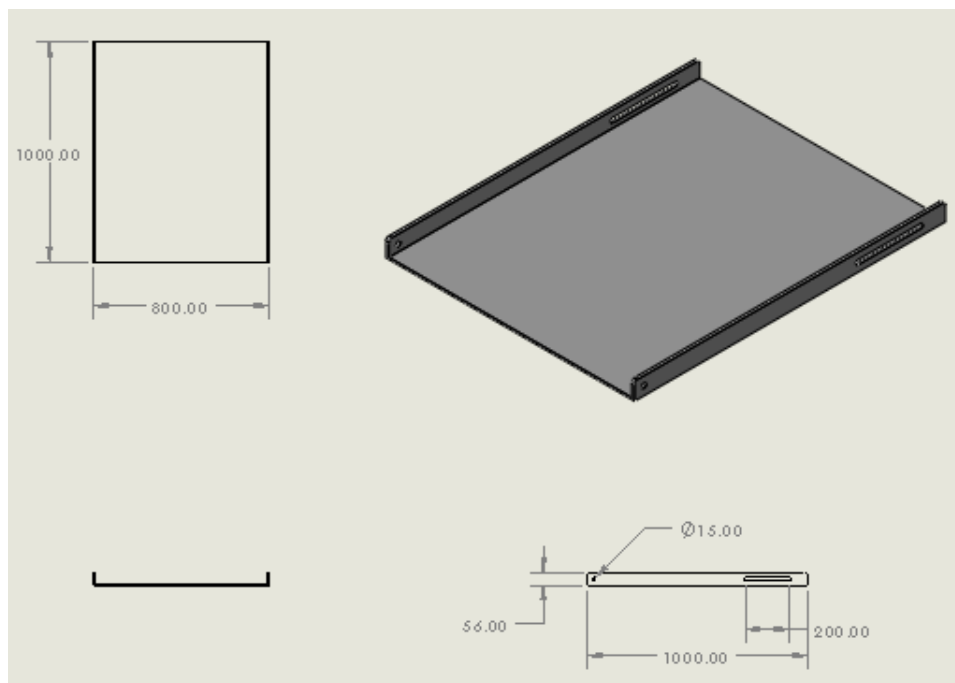

Figure 2. The detail of the base plane (dimension in mm).

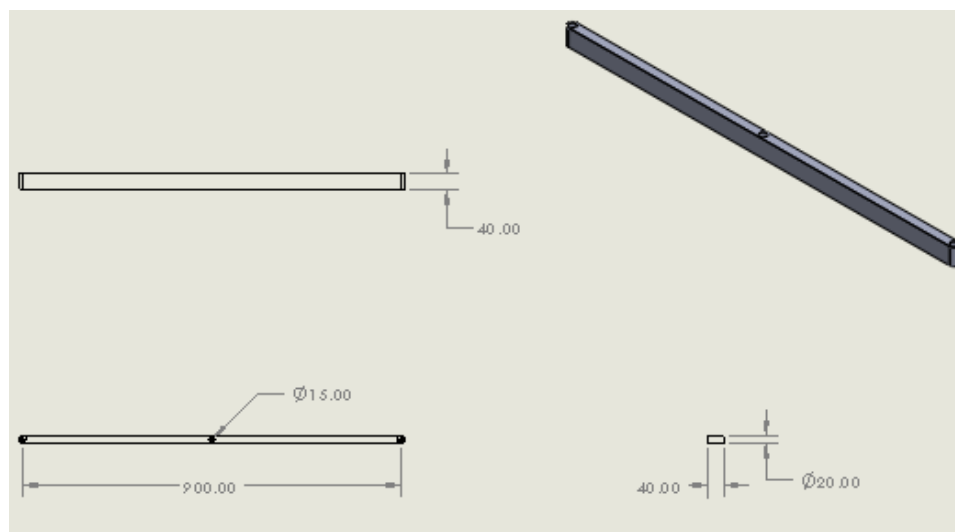

Figure 3. The detail of the link (dimension in mm).

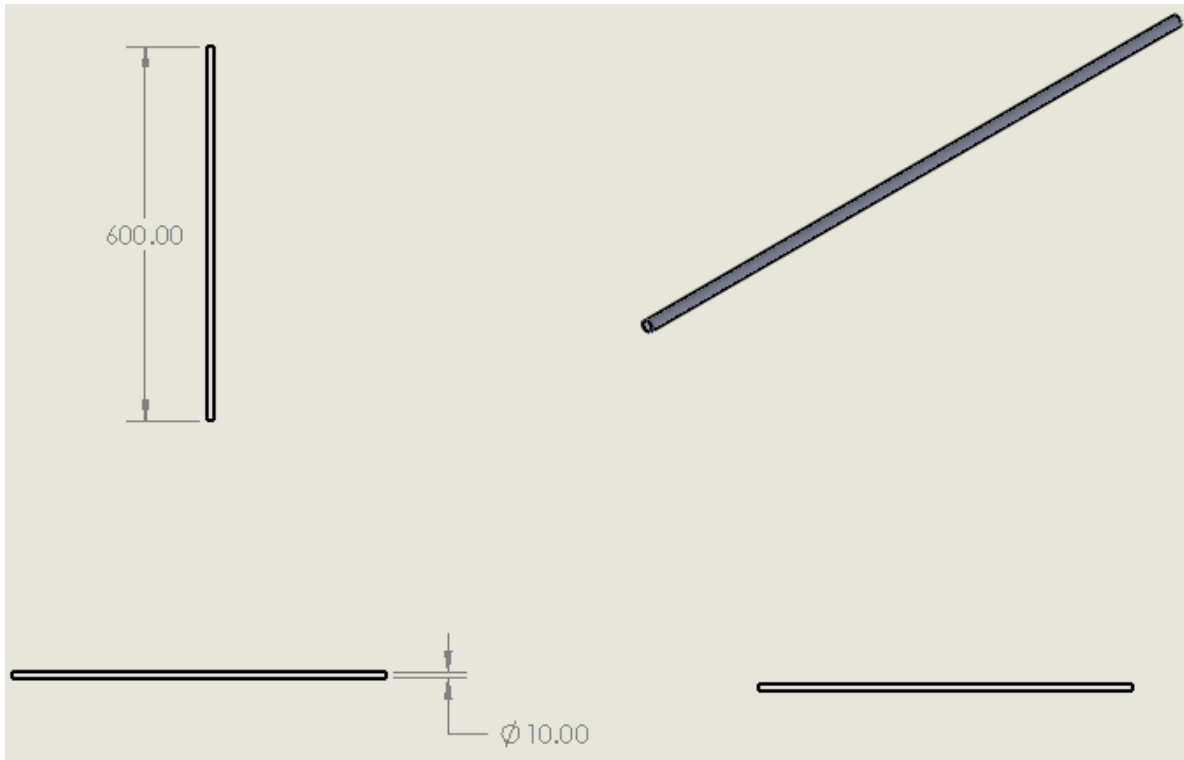

Figure 4. The Detail of the Rod (1) (dimension in mm).

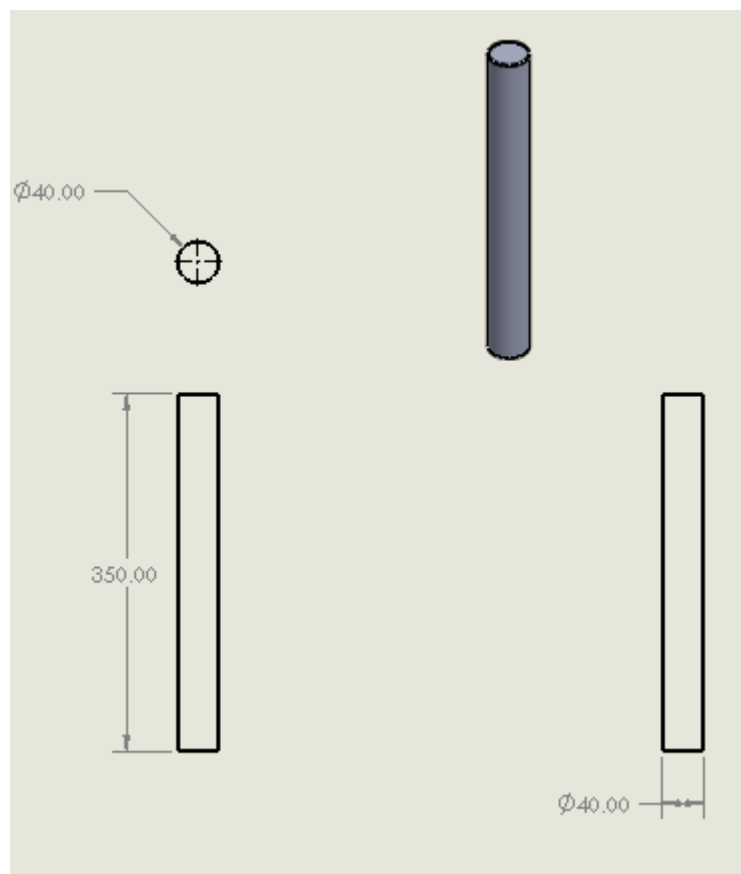

Figure 5 The Detail of the Rod (2) (dimension in mm).

3.3 Strength analysis

Highest position:

The analysis starts from the highest position of the scissor lift mechanism. **Figure 6** is showing the free body diagram of both links in the highest position. Since this is a static loading analysis, hence the acceleration is equal to zero. Then, the loading of the system is only coming from the upper part, which is 37.5 kg on each link or about 367.9 N. Those FBD completed with the reaction force calculated using the sigma moment for the whole scissor mechanism. Then, on doing the stress analysis, the dimension that will be used is the beam's cross-section with a rectangular shape of 10 x 40 x 20 mm.

Having the calculations using SFD and BMD, the considered forced to be analyzed for the safety factor on each link is found. Equations below are the detailed calculation for getting the safety factor.

The maximum normal stress:

$$\sigma_E = \frac{Mc}{I} \quad (1)$$

$$\sigma_E = 42.675 \text{ MPa} \quad (2)$$

Moreover, the maximum shear stress at E is:

$$\tau_E = \frac{3 V_{max}}{2 A} \quad (3)$$

$$\tau_E = 0.474 \text{ MPa} \quad (4)$$

After converting the value of σ_{max} and determine the safety factor can be determined as below. Knowing that $S_{ysteel} = 250 \text{ MPa}$.

$$\tau_{max} < \frac{S_y}{2} \quad (5)$$

$$n = \frac{S_y}{\tau_{max}} \quad (6)$$

$$n = \frac{125}{20.704} \quad (7)$$

$$n = 6.037 \quad (8)$$

where,

σ_E : Maximum normal stress at link AEC (MPa)

M : Bending moment (Nm)

c : Maximum distance from neutral axis (m)

I : Second moment of inertia (m⁴)

τ_E : Maximum shearing stress at link AEC (MPa)

V_{max} : Maximum shearing force (MPa)

A : Area (m²)

S_y : Yield strength (MPa)

n : Safety Factor

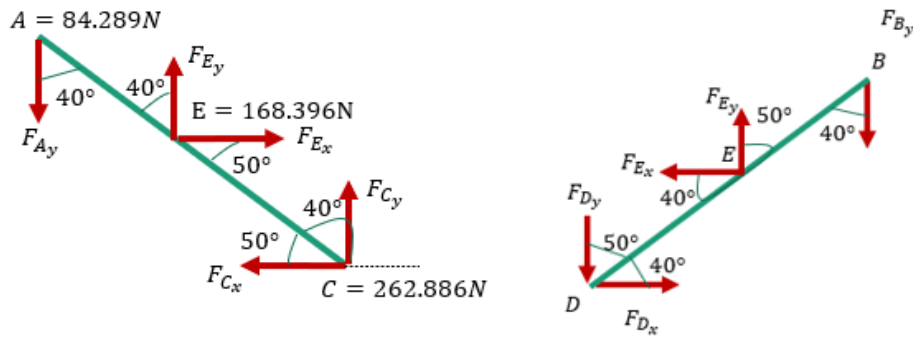

Figure 6. Free body diagram of scissors arm in highest position.

Table 4 shows the summary of the calculation of the result in each link. The calculation is done on the upper mechanism only because the scissors lift assumed as mirrored.

Lowest position:

The same as the highest position, the whole system needs to be analyzed using the moment, F_x , and F_y . After having the complete reaction forces, the FBD for the stress analysis is shown in **Figure 7**.

The FBD in **Figure** calculates the highest stress at each link by finding the SFD and BMD of each link. After getting the maximum normal and shear of each link, then calculate the safety factor. **Table 5** shows the summary of the calculation results on each link.

Table 4. Summary of the calculation result in highest position.

| | Link AEC | Link BED |
|------------------------------|-----------|----------|
| Maximum normal stress at E | 42.675MPa | 80.88MPa |
| Maximum shearing stress at E | 0.474MPa | 1.80MPa |
| Safety Factor | 6.037 | 3.11 |

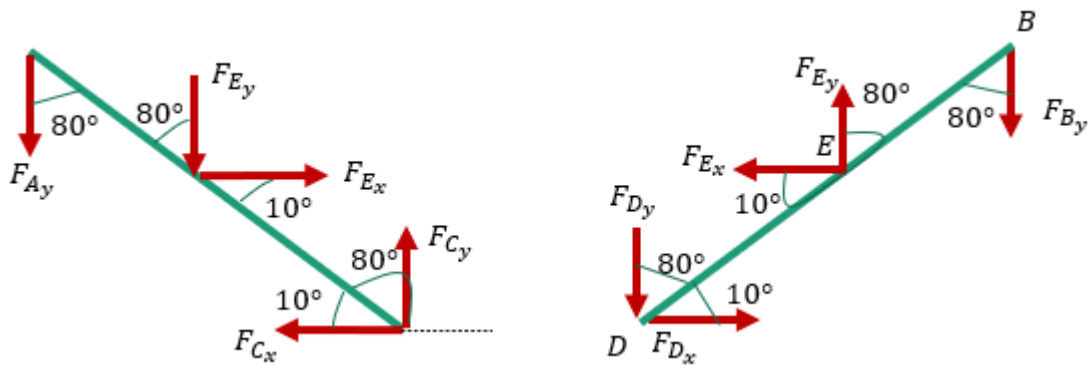

Figure 7. Free body diagram of scissors arm in the lowest position.

Table 5. Summary of the calculation result in lowest position

| | Link AEC | Link BED |
|------------------------------|-----------|------------|
| Maximum normal stress at E | 41.897MPa | 205.552MPa |
| Maximum shearing stress at E | 0.466MPa | 1.797MPa |
| Safety Factor | 7.013 | 1.252 |

3.4 Fatigue analysis

The fatigue analysis is done by considering all design factor calculations of each link and choosing the smallest one as the critical point of the mechanism as it is holding the maximum weight of 150 kg assumptions. The critical point is located on link BED at the lowest position of the mechanism. By input the known stress and torque on link BED into the principal formula, the maximum and minimum stress can be calculated as shown below:

$$\sigma_{max,min} = \frac{\sigma}{2} \pm \sqrt{\left(\frac{\sigma}{2}\right)^2 + \tau^2} \quad (9)$$

$$\sigma_{max,min} = \frac{295.552}{2} \pm \sqrt{\left(\frac{295.552}{2}\right)^2 + 1.797^2} \quad (10)$$

$$\sigma_{max} = 205.568 \text{ MPa} \quad (11)$$

$$\sigma_{min} = -0.016 \text{ MPa} \quad (12)$$

This maximum and minimum stress later can be used to calculate the endurance limit, but it is required to determine the Marin factor first (Nisbett, 2008). Marin factor can be calculated as the following.

$$S_y = 250 \text{ MPa} \quad (13)$$

$$S_{ut} = 500 \text{ MPa} \quad (14)$$

$$S_e' = 250 \text{ MPa} \quad (15)$$

$$k_a = aS_{ut}^b \quad (16)$$

$$k_b = 1 \quad (17)$$

$$k_c = 0.85 \quad (18)$$

$$k_d = k_e = k_f = 1 \quad (19)$$

S_{ut} is the ultimate strength of steel structural A36 steel as the material of the rectangular bar or link. S_e' is the endurance limit factor which is half of the S_{ut} . The link is assumed to use a cold-drawn or machined surface that the value of k_a is 0.8688. Consecutively, k_b or the size factor and k_c or the load factor determined as 1 and 0.85, respectively. Another Marin factor such as k_d , k_e , and k_f are assumed as 1. Therefore, by calculation below, the endurance limit S_e is 184.62 MPa (Nisbett, 2008).

$$S_e = k_a k_b k_c k_d k_e k_f S_e' \quad (20)$$

$$S_e = (0.8688)(1)(0.85)(1)(1)(1)(250) \quad (21)$$

$$S_e = 184.62 \text{ MPa} \quad (22)$$

By knowing all the variables from previous calculations, the fatigue safety factor can be obtained. The calculation is used modified goodman failure criteria as shown below, which obtained the value of 1.31.

$$\sigma_m = \left| \frac{\sigma_{max} - \sigma_{min}}{2} \right| \quad (23)$$

$$\sigma_m = \left| \frac{205.568 - (-0.016)}{2} \right| \quad (24)$$

$$\sigma_m = 102.792 \text{ MPa} \quad (25)$$

$$\sigma_a = \frac{\sigma_{max} + \sigma_{min}}{2} \quad (26)$$

$$\sigma_a = \frac{205.568 + (-0.016)}{2} \quad (27)$$

$$\sigma_a = 102.776 \text{ MPa} \quad (28)$$

$$\frac{\sigma_a}{S_e} + \frac{\sigma_m}{S_{ut}} = \frac{1}{n} \quad (29)$$

$$\frac{102.776}{184.62} + \frac{102.792}{500} = \frac{1}{n} \quad (30)$$

$$0.557 + 0.206 = \frac{1}{n} \quad (31)$$

$$n = 1.31 \text{ (infinite)} \quad (32)$$

where,

| | |
|----------------|---|
| σ_a | : Component of the amplitude (MPa) |
| σ_m | : Component in the midrange (MPa) |
| σ_{max} | : Maximum value of stress (MPa) |
| σ_{min} | : Minimum value of stress (MPa) |
| σ'_a | : Stress by MSS (MPa) |
| S_e | : Endurance limit by marine factors (MPa) |
| S'_e | : Endurance limit by Ultimate strength (MPa) |
| k_a | : Condition of the surface in modification factor |
| k_b | : Modification factor's sizes |
| k_c | : The load in the modification factor |
| k_d | : Modification factor's temperature |
| k_e | : The factor of reliability |
| k_f | : The miscellaneous effect of the modification factor |
| S_{ut} | : The ultimate strength (MPa) |

According to the statics and dynamics analysis that has been done, it showed that the proposed design is safe for operations. In the statics analysis, the design factor is more than 1 for every single link, which means each component of the mechanism is in safe. Then, in the analysis of the dynamics, the fatigue safety factor has the value of 1.31, which means the mechanism has been predicted to have an infinite service life. However, the prevention and monitoring activities are still needed to be conducted in case of any sudden failure.

4. CONCLUSION

A lifting mechanism for home appliances has been introduced in this paper to offer a solution for securing the electronic device during the flood. This design mechanism was created by identifying needs, defining a problem, specifications, design invention, analysis and optimization, and evaluation. The device used a hydraulic as the primary mechanism to combine scissors-hydraulic mechanism to lift the electronic device to the safe state above the flood. The strength analysis of the critical point of the material was calculated using a static and fatigue loading analysis at the lowest and highest position of the mechanism. It comes up with the result of a minimum safety factor of 1.225 as the critical point of the mechanism and 1.31 of goodman fatigue failure factor. The value indicates the mechanism is safe and infinite

fatigue life. Moreover, the result can be referred to as a lecture note for the machine element course in a mechanical engineering major.

5. ACKNOWLEDGEMENTS

We say thank you to the supervisors who have helped us in the preparation of this scientific paper. We are also very grateful to respondents who helped us with data collection.

6. AUTHORS' NOTE

The authors declare that there is no conflict of interest regarding the publication of this article. The authors confirmed that the paper was free of plagiarism.

7. REFERENCES

- Bacchini, A., Cestino, E., Van Magill, B., and Verstraete, D. (2021). Impact of lift propeller drag on the performance of eVTOL lift+cruise aircraft. *Aerospace Science and Technology*, 109(2021), 106429.
- Çalik, A. (2009). Effect of cooling rate on hardness and microstructure of AISI 1020, AISI 1040 and AISI 1060 Steels. *International journal of Physical sciences*, 4(9), 514-518.
- Kayhani, N., Taghaddos, H., Mousaei, A., Behzadipour, S., and Hermann, U. (2021). Heavy mobile crane lift path planning in congested modular industrial plants using a robotics approach. *Automation in Construction*, 122(2021), 103508.
- Hasan, M. F. (2016). Analysis of mechanical behavior and microstructural characteristics change of ASTM A-36 steel applying various heat treatment. *Journal of Material Science and Engineering*, 5(2), 1-6.
- Budynas, R. G., Nisbett, J. K., and Tangchaichit, K. (2005). *Shigley's mechanical engineering design* (pp. The-McGraw). New York: McGraw Hill.
- Oktaviandri, M., and Paramasivam, D. A. (2020). Design and Fabrication of Customized Ais Kacang Vending Machine. *Indonesian Journal of Computing, Engineering and Design (IJoCED)*, 2(1), 24-31.
- Paramasivam, V., Tilahun, S., kerebih Jembere, A., and Selvaraj, S. K. (2021). Analytical investigation of hydraulic scissor lift for modular industrial plants in ethiopia. *Materials Today: Proceedings*.
- Preedawiphath, P., Mahayotsanun, N., Sa-ngoan, K., Noipitak, M., Tuengsook, P., Sucharitpwatskul, S., and Dohda, K. (2020). Mechanical Investigations of ASTM A36 Welded Steels with Stainless Steel Cladding. *MDPI Coatings 2020*, 1-17.
- Rashid, H., Ariffin, M. K. A. M., Noh, M. H. M., Abdullah, A. H., Hamid, A. H. A., Jusoh, M. A. M., and Othman, A. (2012). Design review of scissors lifts structure for commercial aircraft ground support equipment using Finite Element Analysis. *Procedia Engineering*, 41(2012), 1696-1701.
- Sajid, H. U., and Kiran, R. (2018). Influence of stress concentration and cooling methods on post-fire mechanical behavior of ASTM A36 steels. *Construction and Building Materials*, 186(2018), 920-945.

- Statista Research Department. (2021). Indonesia: number of floods 2019 | Statista. Retrieved on 10 April 2021 in <https://www.statista.com/statistics/954377/indonesia-number-floods/>
- Tambunan, M. P. (2017, February). The pattern of spatial flood disaster region in DKI Jakarta. In *IOP Conference Series: Earth and Environmental Science*, 56(1), 012014.
- Zulaikah, S., Rahmanda, W. H., and Triawan, F. (2020). Foldable Front Child-Seat Design for Scooter Motorcycle: Strength Analysis Under Static and Dynamic Loading. *International Journal of Sustainable Transportation Technology*, 3(2), 37-44.